

1

2

3

4

NOTES:

- 1. BAY 1: DOOR
- 2. BAY 2: DOOR
- 3. BAY 3: DOOR

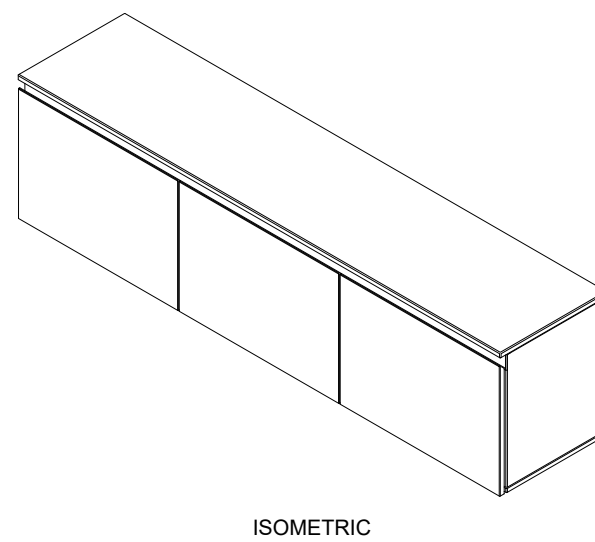
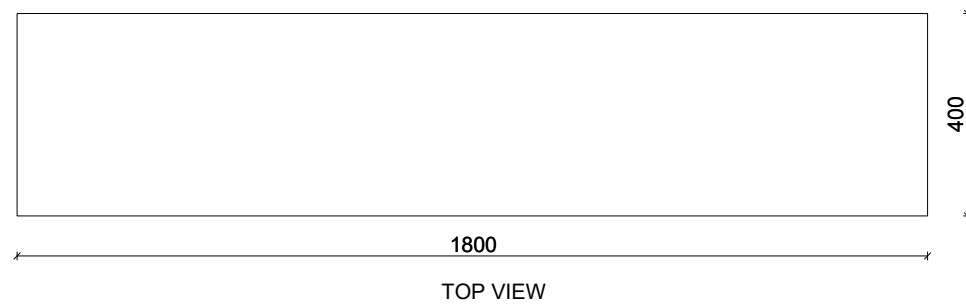
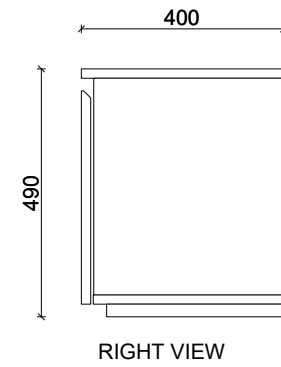
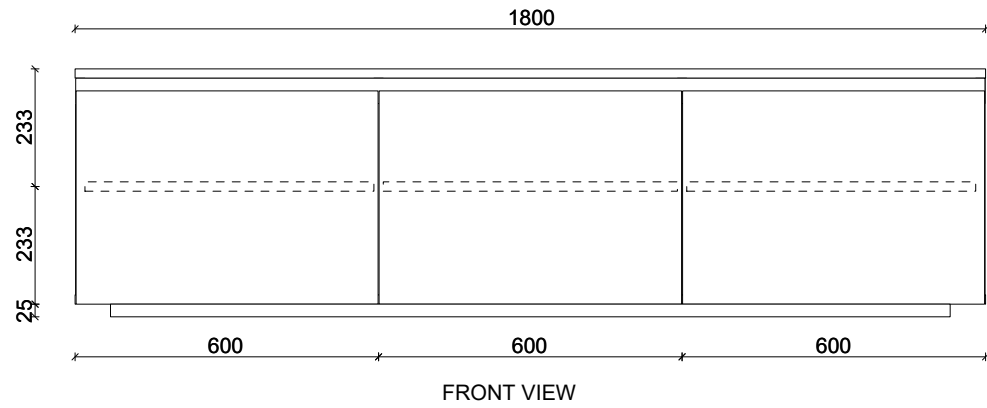

CLIENT

PROJECT NO. / NAME

PRODUCT CODE	DRAWING NO.
--------------	-------------

DRAWING TITLE

KURA UNIT - 1800 x 400 x 490 MM

DRAWN	DATE	PRODUCTION	DATE
-------	------	------------	------

CFG	25-MAY-2021		
-----	-------------	--	--

CHECKED	DATE	APPROVED	DATE
---------	------	----------	------

A3	SHEET	DRAWING SCALE	REV
----	-------	---------------	-----

1 OF 1	1 : 15	a.0
--------	--------	-----

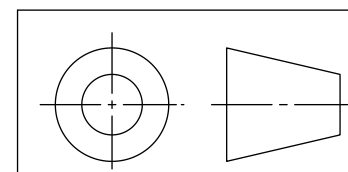
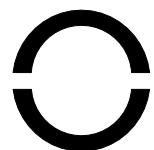

NOMI
ALL RIGHTS RESERVED
THIS DRAWING IS COPYRIGHT AND REMAINS THE PROPERTY OF
NOMI. THIS DRAWING IS ISSUED IN CONFIDENCE, AND
MAY NOT BE ALTERED, COPIED, TRANSFERRED, SOLD OR
OTHERWISE DISCLOSED WITHOUT WRITTEN PERMISSION
FROM NOMI.

NOMI

Suite 508
19A Boundary St,
Rushcutters Bay, NSW
Australia, 2011

1

2

3

4

B

A